

DD/DD-CG/DD-L SERIES

Deluxe Ice Cream Dipping/Display Merchandisers

STANDARD MODELS

- DD-26
- DD-46
- DD-66
- DD-88

CURVED GLASS MODELS

- DD-26CG
- DD-46CG
- DD-66CG
- DD-88CG

LOW GLASS MODELS

- DD-26L
- DD-46L
- DD-66L
- DD-88L

FEATURES

CONSTRUCTION

- Attractive, contemporary design
- Equipped with leveling legs to correct for unlevel flooring situations
- Rear air intake and discharge eliminates front grille and allows full front of cabinet for graphics
- Independent on/off compressor and light switch
- Stainless steel top and attached superstructure
- 24 gauge white painted galvanized steel interior and exterior
- Tempered plate glass viewing window
- Drain with garden hose connector for ease of cleaning
- Brilliant, interior fluorescent lighting
- Stainless steel serving deck
- Top and side lid wiper gaskets

- Heavy-duty epoxy-coated wire can support racks
- 9 ft. long cord with molded plug
- 2 1/4" foamed-in-place "zero ODP" urethane insulation
- Number and length of interior light fixtures:
 - DD-26/26CG/26L ... (1) 18"
 - DD-46/46CG/46L ... (1) 36"
 - DD-66/66L.... (1) 18", (1) 36"
 - DD-66CG..... (2) 18"
 - DD-88/88CG/88L ... (2) 36"

FINISH

- Sparkling white enamel interior and exterior

LIDS

- Hinged, high-tensile, transparent acrylic dipping compartment lids with full length handle

REFRIGERATION

- Refrigerant:
 - DD-26/26CG/26L, DD-46/46CG/46L....R-134a
 - DD-66/66CG/66L, DD-88/88CG/88L... R-404A
- Cold wall evaporator
- Low maintenance bare tube condenser coil on all models except DD-26/26CG/26L
- No minimum clearance required on cabinet sides but front, back and top must be left open for customer and operator access
- Temperature range: 5° to -5°F (-15° to -21°C)
- R-factor (insulation efficiency rating): 19.40

WARRANTY

- Standard limited 4 year extended compressor and one year limited parts and labor



DD/DD-CG/DD-L SERIES

DELUXE ICE CREAM DIPPING/DISPLAY MERCHANDISERS

OPTIONS

- Rear service doors for DD-46, DD-66 and DD-88 models (factory installed)
- Custom colors
- Removable can holders with white overnight can covers
- Dipper well
- Removable frost shields
- Leg kit
- Casters
- Lid locking kit (less locks)
- Flavor identification tabs (for DD and DD-CG models only)
- Ice cream pan rack assembly (pans not included)

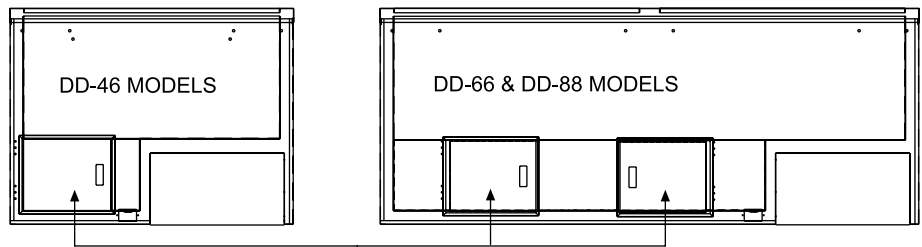
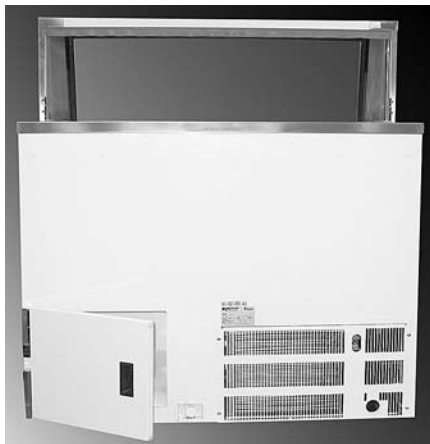

11.75" x 14.625" DOOR OPENING

DOOR SIZE: 13.25" X 16.125"

REAR SERVICE DOOR FOR DD-46, DD-66 AND DD-88



FROST SHIELDS



LID LOCKING KIT



CAN HOLDERS

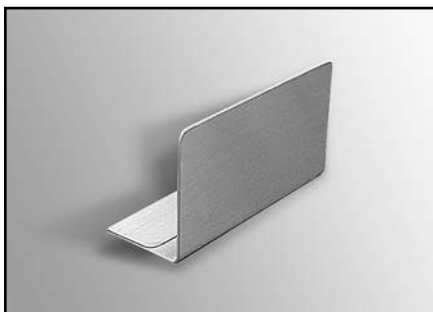

FLAVOR IDENTIFICATION TAB

TECHNICAL SPECIFICATIONS

MODEL	DIMENSIONS (in.)			DIMENSIONS (mm)			VOLTS	AMPS	UNIT H.P.	CAN CAP.** DISPLAY/STORAGE	CAP. CU. FT.*	SHIP CU. FT.	SHIP WT. LB/KG
	L	D	H	L	D	H							
DD-26/26CG/26L	26 ¹ / ₂	27 ³ / ₄	*	673	705	*	115	7.4	1/3	4/0	3.5	38.0	240/109
DD-46/46CG/46L	47 ³ / ₄	27 ³ / ₄	*	1213	705	*	115	7.5	1/2	8/4	9.6	54.0	370/168
DD-66/66CG/66L	69 ¹ / ₄	27 ³ / ₄	*	1759	705	*	115	9.7	1/2	12/8	16.0	76.0	495/225
DD-88/88CG/88L	90 ³ / ₄	27 ³ / ₄	*	2305	705	*	115	11.5	3/4	16/12	22.5	97.0	600/273

*Height of standard and low glass models: 50" (1270mm), curved glass models: 52" (1321mm). **Capacities in 9¹/₂" diameter, 3 gallon cans.

†Measured to the load line level.

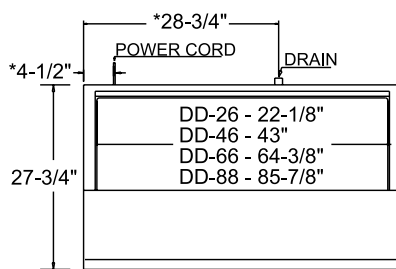

*DISTANCES ARE STANDARD ON ALL MODELS

PLAN VIEW

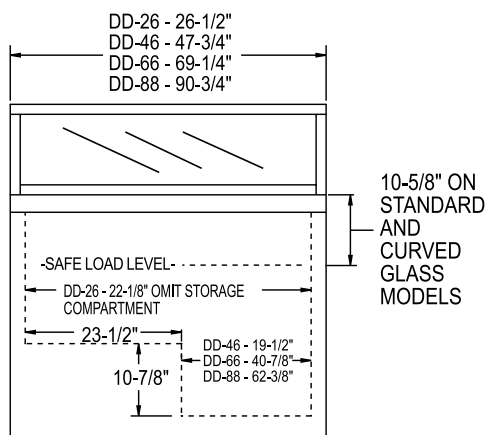

STANDARD & CURVED GLASS ELEVATION VIEW

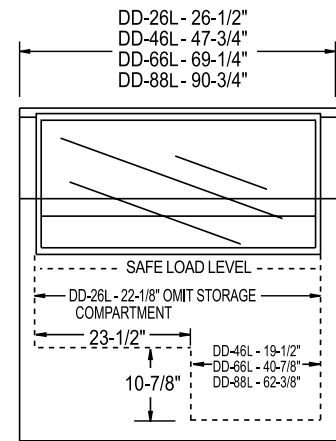

LOW GLASS ELEVATION VIEW

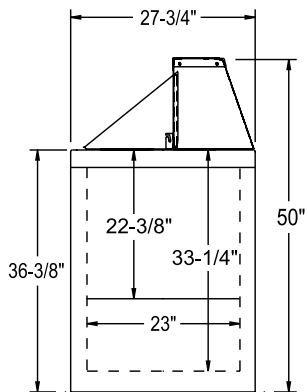

STANDARD SIDE VIEW

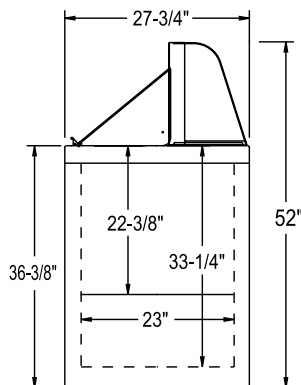

CURVED GLASS SIDE VIEW

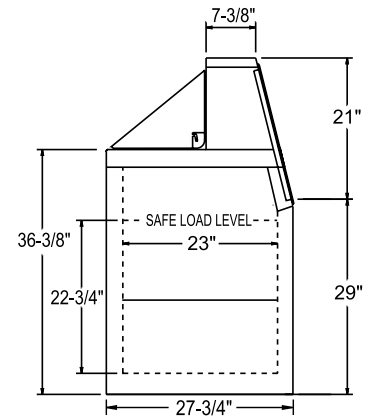

LOW GLASS SIDE VIEW

LISTINGS



HOOKUP

Via plug in, 9 foot long, flexible 3 wire 14/3 cord with molded plug. Drain hookup has standard garden hose connection.





DD/DD-CG/DD-L SERIES

DELUXE ICE CREAM DIPPING/DISPLAY MERCHANDISERS

BID SPECIFICATIONS

Item no. DD-_____

Provide _____ ()

Deluxe Ice Cream Dipping/Display Merchandiser(s), Master-Bilt model no. DD-_____.

Cabinet to have independent on/off compressor and light switch. Cabinet to be provided with drain connection, stainless steel top and superstructure, tempered plated glass viewing window and interior fluorescent lighting. Cabinet is to have rear air intake

and discharge. Standard leveling legs provided to correct for un-level flooring situations. Hanging frost shields with mounting screws offered as an option (consult your Master-Bilt representative for additional options).

Cabinet will be provided with 9 foot cord and molded plug.

DD-26/26CG/26L and DD-46/46CG/46L will use R-134a refrigerant while DD66/66CG/66L and DD-88/88CG/88L will use

R-404A refrigerant. The temperature range will be 5° to -5°F (-15° to -21°C). All models except DD-26/26CG/26L to be supplied with a refrigeration system containing low maintenance bare tube condenser coil.

Cabinet to have standard limited four year extended compressor warranty and one year limited parts and labor warranty. Cabinet to be UL, C-UL and NSF listed.

NOTE: Cabinet designed for optimum performance in air-conditioned area at 75°F ambient and 55% relative humidity. All specifications subject to change without notice.



908 Highway 15 North • New Albany, MS 38652

PHONE: 800-647-1284 or 662-534-9061 • FAX: 800-232-3966 or 662-534-6049 • www.master-bilt.com

