



QMPM-48

## QMPM SERIES

### Quantum Series Medium Temp Open Display Merchandisers

#### MODELS

- QMPM-36
- QMPM-48
- QMPM-72

## FEATURES

### CONSTRUCTION

- 24 gauge white painted galvanized steel interior and exterior
- Removable two-tier stainless steel display deck
- Full length 8<sup>3</sup>/<sub>4</sub>" wide laminated white formica counter top
- Automatic defrost
- On/off power switch (QMPM-36 and QMPM-48 only)
- Cord and plug (QMPM-36 and QMPM-48 only)
- 1<sup>5</sup>/<sub>8</sub>" foamed-in-place "zero ODP" urethane insulation

### FINISH

- White enamel interior and exterior

### REFRIGERATION

- Refrigerant: R-134a
- Front air intake and rear discharge
- Electric condensate evaporator (QMPM-72 requires a separate 115V power supply for evaporator)
- Forced air ducted flow
- Self-contained, bottom mount refrigeration system
- Temperature range: 34° to 41°F (1° to 5°C)
- R-factor (insulation efficiency rating): 14.01
- Minimum clearance: 10" air space at top, 6" at rear and 0" at each side. Extra space allows for circulation of air behind the case and prevention of condensation on the exterior surfaces.

### WARRANTY

- Standard limited four year extended compressor and one year limited parts and labor

## OPTIONS

- Add suffix "SS" for stainless steel interior and exterior
- Custom exterior colors
- Night curtain kit
- Light kit
- Night curtain/light kit
- Casters
- Sandwich racks
- Sandwich rack dividers
- 1" vinyl bumper in choice of black, blue, brown, green, red or white



# QMPM SERIES

## QUANTUM SERIES MEDIUM TEMP OPEN DISPLAY MERCHANDISERS

### TECHNICAL SPECIFICATIONS

MODEL	DIMENSIONS (in.)			DIMENSIONS (mm)			VOLTS	AMPS	UNIT H.P.	CAP. CU. FT.	SHIP CU. FT.	SHIP WT. (LB/KG)
	L	D	H	L	D	H						
QMPM-36	36	30	43 1/4	914	775	1099	115	10.3	1/3	3.7	42.0	310/141
QMPM-48	48	30	43 1/4	1219	775	1099	115	15.5	1/2	5.1	54.0	410/220
QMPM-72	72	30	43 1/4	1829	775	1099	115/115*	15.8/10.4*	3/4	7.9	87.0	610/277

\*Electric condensate evaporator requires separate power supply.

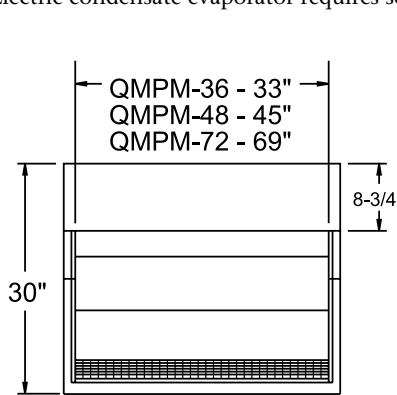

PLAN VIEW

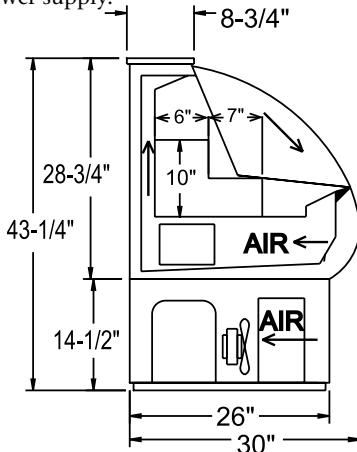

SIDE VIEW

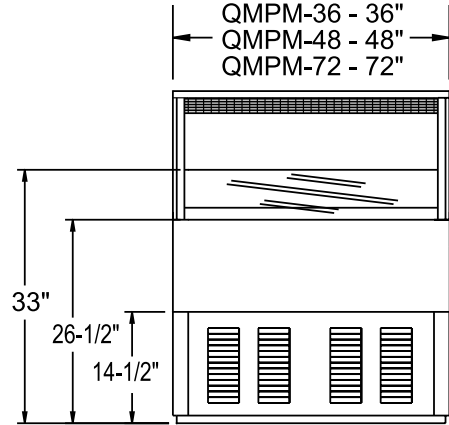

ELEVATION VIEW

### LISTINGS



### HOOKUP

QMPM-36 and QMPM-48 via plug in, 9 foot long, flexible 3 wire 14/3 cord with molded plug. QMPM-72 model hardwired with separate 115V junction boxes for cabinet and condensate evaporator.

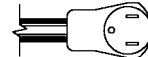

NEMA 5-15P (QMPM-36)

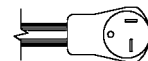

NEMA 5-20P (QMPM-48)

### RECOMMENDED OPERATING CONDITIONS

- Merchandisers designed to hold product in the 34° to 41°F (1° to 5°C) range
- Designed to operate in air-conditioned stores where the maximum temperature is 75°F and the maximum relative humidity is 55%

- Should not be installed in direct sunlight
- Should not be installed near HVAC vents, fans or doorways that will disrupt airflow and compromise the function of the air screen inside the case
- Bottom shelf should not be loaded such

- that the front air intake is obstructed
- Factory installed controls should not be altered, removed or replaced without consent of the factory
- Product must not be displayed in the cold air curtain

### BID SPECIFICATIONS

Item no. QMPM-\_\_\_\_\_  
 Provide \_\_\_\_\_ ( ) Quantum Series Medium Temp Open Display Merchandiser(s), Master-Bilt model no. QMPM-\_\_\_\_\_.  
 Merchandiser to have removable two-tier stainless steel display deck, full length

8 3/4" wide laminated white formica counter top, automatic defrost, on/off power switch (QMPM-36 and QMPM-48 only) and have foamed-in-place "zero ODP" urethane insulation. The refrigeration system is to be self-contained, have a front condenser air intake and rear discharge

and use R-134a refrigerant. The temperature range will be 34° to 41°F (1° to 5°C). Merchandiser to have standard limited four year extended compressor warranty and one year limited parts and labor warranty. Merchandiser to be UL and C-UL listed and UL EPH classified.

NOTE: All specifications subject to change without notice.



908 Highway 15 North • New Albany, MS 38652  
 PHONE: 800-647-1284 or 662-534-9061 • FAX: 800-232-3966 or 662-534-6049 • www.master-bilt.com

