



SaniServ[®]
An AFFINIS GROUP Company

Item No. _____
Quantity _____
Job Name _____

Designed For Higher Volume Applications
Seven – 4 oz. Servings per Minute – 20 Qt. Capacity
Great for Restaurants, Buffets, & Ice Cream Shops

Model 614SAS
Floor Model
Select-A-Shake
Machine

The **SaniServ** Model 614SAS Shake Machine provides up to four flavors of uniform, smooth, high profit shakes! Using a CO² process to mix flavors while shake product is dispensed, customers will always have their favorite flavor available with no extra mixing and measuring! Owners and operators will appreciate the machine's quick recovery time and ability to provide everyone's favorite flavor quickly even during peak operating periods! The 614SAS can satisfy everyone with their favorite flavor every time!

Space Saving

Compact Floor Model Design - **SaniServ** model 614SAS provides a high volume of milk shake in the traditional floor model design. Operators can turn that valuable floor space into a high profit center by providing consistent high quality shakes customers demand.

Easy Cleaning and Operation

Fewer Parts = Simplified Cleaning – **SaniServ** equipment is designed and built with the fewer parts to be disassembled, cleaned and sanitized than any other machine in the industry.

High Return on Investment

Increased Profits – **SaniServ** machines combine efficiency with consistent product quality and fast quiet operation while insuring customer satisfaction with high profit ice cream or yogurt products.

Quality Design

Durability – **SaniServ** machines are built to achieve long and dependable life through simplicity of design. Every machine is shipped standard with a stainless steel exterior, durable steel interior frame construction, heavy-duty components and consistency systems.



Made in the USA

SaniServ Model 614SAS

Floor Model Shake Freezer

For sales information contact: Rodway 204-786-4881

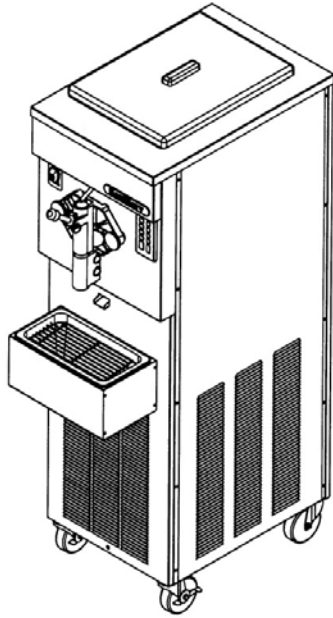

Minimum Wall Clearance
Both Sides and Back -
6 inches (152 mm)

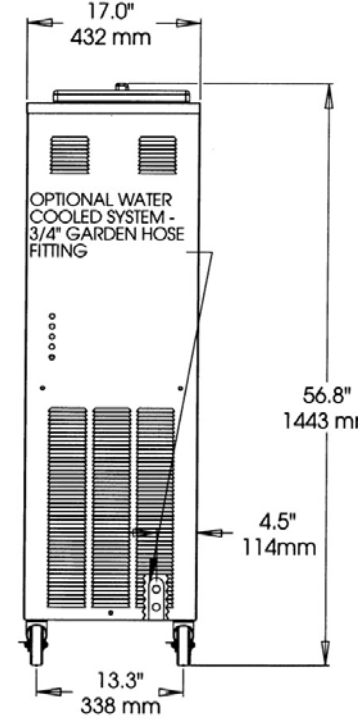
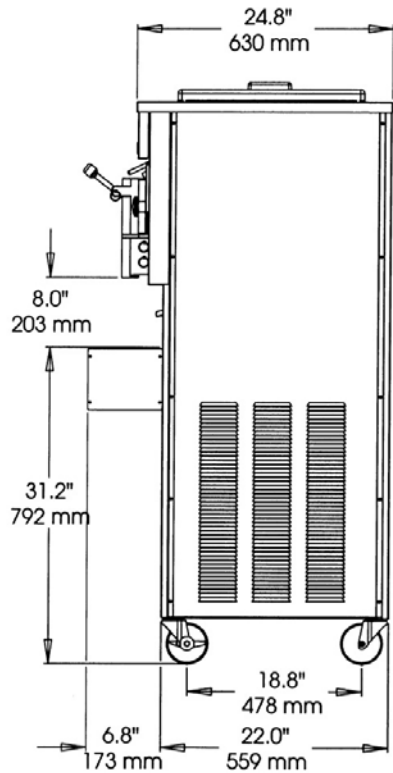

ELECTRICAL				WIDTH INCHES (mm)	HEIGHT INCHES (mm)	DEPTH INCHES (mm)	WEIGHT LBS. (Kg)	VOLUME CU FT. (cu. m.)
VOLTS	Hz	Ph.	Amps					
208-230	60	1	15	17 (432)	56.8 (1443)	24.8 (630)	352 (153)	
208-230	60	3	20					
Shipping Specifications				24.5 (622)	58.1 (1476)	40.5 (1028)	382 (173)	32.5 (.92)

Specifications:

- Cooling System:** Air or Water
- Dasher and Compressor Motors:**
1/2 HP Dasher 2 HP Compressor
- Refrigerant Type:** R404A
- Listings:** UL, cUL, NSF

This unit requires CO² connection and a water line connection. The unit comes with 10' syrup line, (3) three gallon canisters, and one regulator.

Features:

- Evaporator and Mix Reservoir Capacity:** 20 Quarts (18.9 liters)
- Dasher:** Heavy-Duty Stainless Steel with low friction scraper blades.
- Controls:** Automatic consistency controls for improved consistency.
- Tamper Proof Automatic Visual Mix Out System**

Warranty:

- Parts 1 year
- Compressor 5 years
- Evaporator 5 years

Options:

- Tune Up Kit
- Parts Tray
- Syrup Rail
- Drink Spinner
- Water Cooled - 3/4" Garden Hose Fitting
- Wash Out Kit - 3/8" Flare Fitting

We reserve the right to change specifications and product design without notice. Such revisions do not entitle the buyer to corresponding changes, improvements, additions or replacements for previously purchased equipment.