



**LOW ENERGY CONSUMPTION**  
Thanks to its refrigerant system, its insulation, the VTA curved meat cases guarantee big savings on energy.



**ENVIRONMENTAL CARE**  
The refrigerant used on TORREY products is CFC's free, which does not damage ozone layer.



**HYGIENE AND EXCELLENT PRESENTATION**  
Stainless steel top provides a long lasting sanitary appearance

Specifications:

MODEL	VTA-200	VTA-250
Capacity (cubic feet)	55 cubic feet	75 cubic feet
Capacity (liters)	746.8 lt	933.5 lt
Exhibition Temperature range	-2 to 2 °C / 28 to 36 °F	
Storage Temperature range	-10 to -3°C / 14 to 27 °F	
Interior finish	Corrosion resistant white finish with stainless steel shelves	
Finish	Corrosion resistant white finish and stainless steel top	
Doors	2	2
Exhibition levels	2	2
Lamps	4 (32 w)	4 (32 w)
Insulation	Foamed in place high density polyurethane	
Refrigerant	R-22	
Cooling system	Forced air cascade system in storage area and gravity system in the exhibition area	
*Volts	127 V/60 Hz (lights), 220 V single phase (compressor)	
Compressor	3/4 HP/ .878 kw	1HP/ 1.74 kw
Net Weight	350 kg/ 770 lb	437 kg/961lb

\* 50 Hz (optional)

**DIMENSIONS**

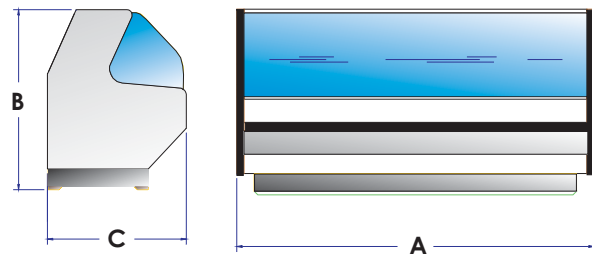

	VTA-200	VTA-250
<b>A</b>	200.8 CM / 79 1/16"	252 CM / 99 1/4"
<b>B</b>	135.2 CM / 53 "	135.2 CM / 53 "
<b>C</b>	103 CM / 40 3/4 "	103 CM / 40 3/4 "

**TEMPERATURE OPERATION RANGE**

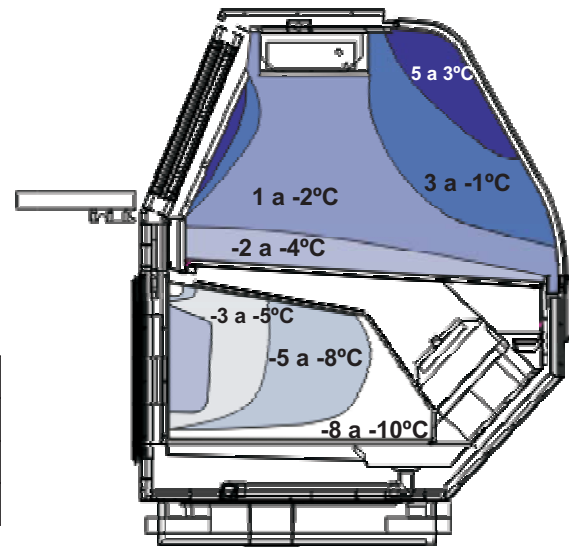

Upper level has no air circulation, this way meat will not dehydrate.

Lower level is the storage area, there is air circulation and is the freezing area of the meat case.

VTA's higher air humidity levels will keep your products moist longer and will reduce your losses due to evaporation



DISTRIBUTED BY



ALL INFORMATION IS SUBJECT TO CHANGE WITHOUT NOTICE



**CURVED GLASS MEAT CASE**

**High quality exhibition**

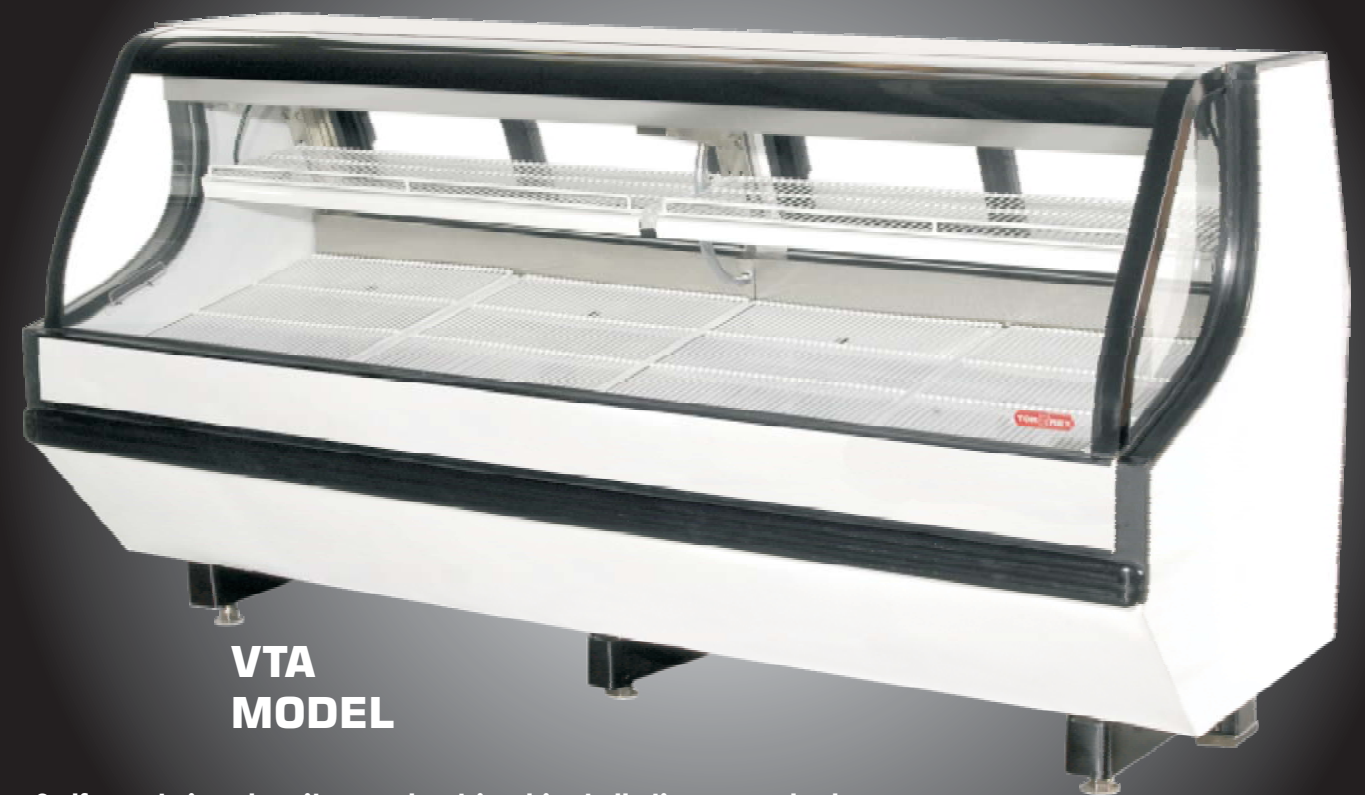

**VTA MODEL**

- Self contained unit, no electrical installation needed.
- Curved glass
- 2 exhibition levels
- Storage area
- Working table
- Frontal bumper
- Forced air cascade and gravity cooling system
- Rear sliding glass doors
- Solid doors at the storage area
- Adjustable feet



## 2 PANE CURVED TEMPERED GLASS

The two pane frontal glass of the TORREY VTA-200 & 250 meat cases, besides duplicating insulation, avoids condensation on the glass in high conditions of humidity.

¡ Recover your investment in less than 6 months!

### Real Experiment

MODEL	QUANTITY	LOSS PER DEHYDRATION	PERIOD
VTA	1 KG	34 Gr	7 DAYS
"X"	1 KG	120 Gr	7 DAYS

This means :  
 0.86 gr difference x 300 Kg weekly sales = 25 Kg x 6 US Dollars per kg.  
 25 Kg x 60 US Dollars / Kg = 150 US Dollars (weekly savings)  
**Monthly savings** ..... 150 US Dollars x 4 weeks = **\$600 US Dollars per month.**  
**Yearly savings** ..... 600 US Dollars x 12 months = **\$7,200 US Dollars per year.**

86 gr

Increase profits with the VTA, you will not have loss because of dehydrated products and evaporation, this equipment pays for itself in less than six months, depending on the use conditions and load, keeps products moist longer, it means more product, more money!



## SPECIAL ADJUSTABLE SHELVES FOR CAKE EXHIBITION (OPTIONAL)

Special devices make shelves to be in horizontal position (with no inclination)

Cakes will look great with no drips, and will attract your customer's attention.

NORMAL INCLINATION

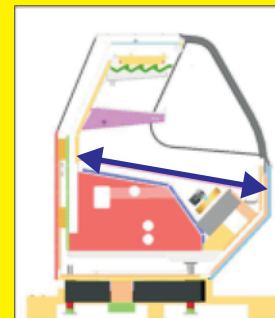

SHELVES ADAPTED TO EXHIBIT CAKES

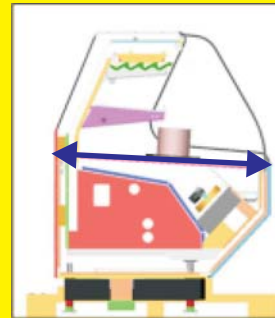

## 2 EXHIBITION ADJUSTABLE LEVELS

Two exhibition levels for great exhibition, (special illumination for low temperatures optional) and most advantage of storage spaces have been taken. Vinyl coated wire shelves are removable

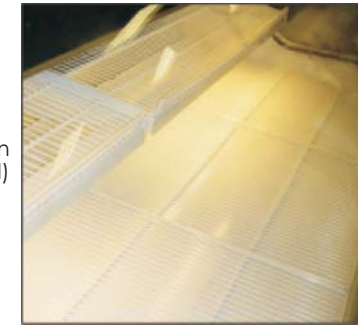

## GREAT EXHIBITION

The VTA model offers maximum visibility to attractively showcase products and with its curved glass brings modernity to your store.

## WORKING TABLE

It features back working table, easily removable.



## WIDE STAINLESS STEEL TOP

Wide stainless steel top, useful as working table, fits a TORREY electronic scale or a meat slicer.

## ADJUSTABLE FEET

It features adjustable feet facilitating floor cleaning and can be adjusted in case of an uneven.



## FRONTAL BUMPER

Its frontal bumper protects the meat case in case of possible impacts

## STORAGE AREA

Great capacity in the storage area



4 rear sliding glass doors, easy to remove for an easy access and three lower solid doors, allow an easy product load and download.